

# Handling Precautions

## ■ Soldering (For only reflow soldering)

1. Recommended P.C. Board pattern (Unit: mm)  
Please use both side of P.C.B.

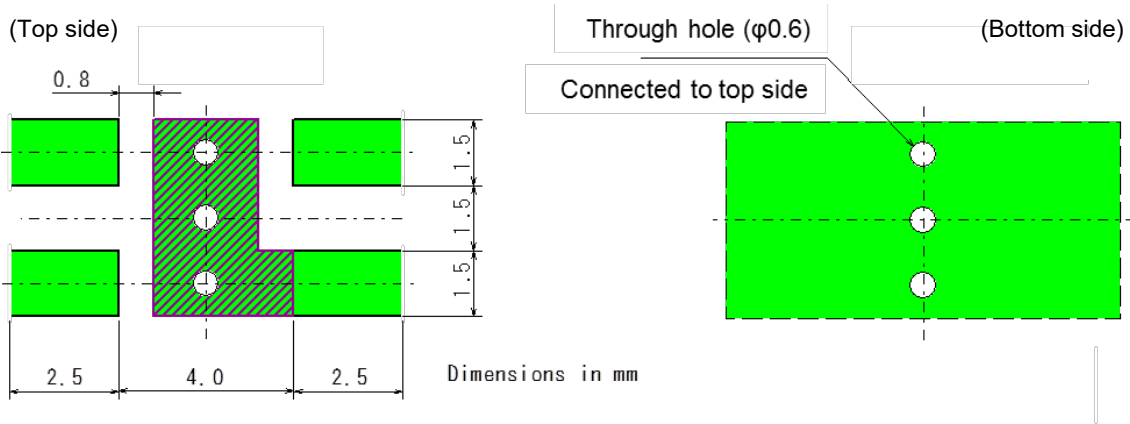

## 2. General cautions for soldering

For soldering, please perform a temperature pattern of the right note for reference.  
Please do not perform heating more than 260 degrees Celsius 10seconds.  
I received the internal joining, but I melt, and such as a short circuit, opening, a gap of a case may occur.  
This part is the lead-free correspondence kind that I received.

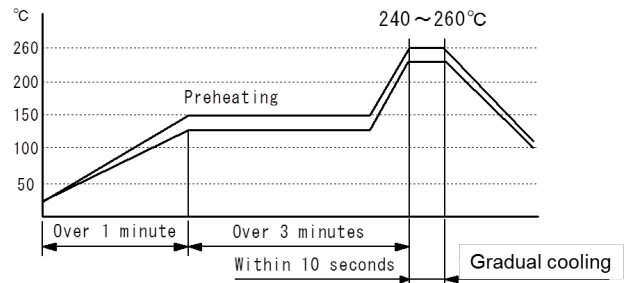

## ■ Taping

Tape size (Tape material: Plastic)

(Unit: mm)

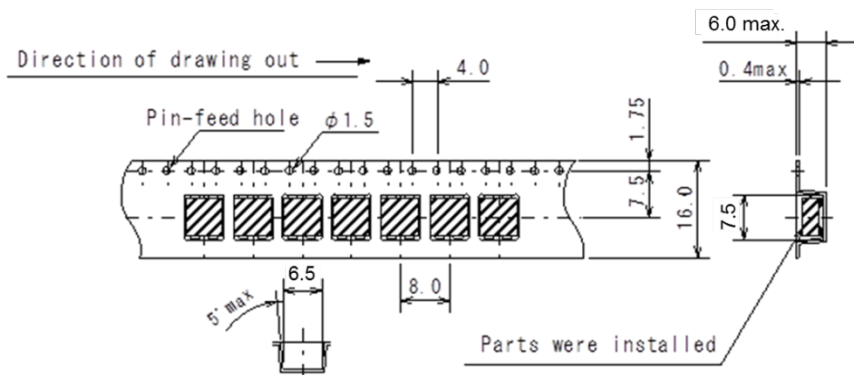

## ■ Packaging Quantity

Type	Package quantity
Taping quantity	1,000pcs / reel