

## 详细包装状态

### ■卷带规格

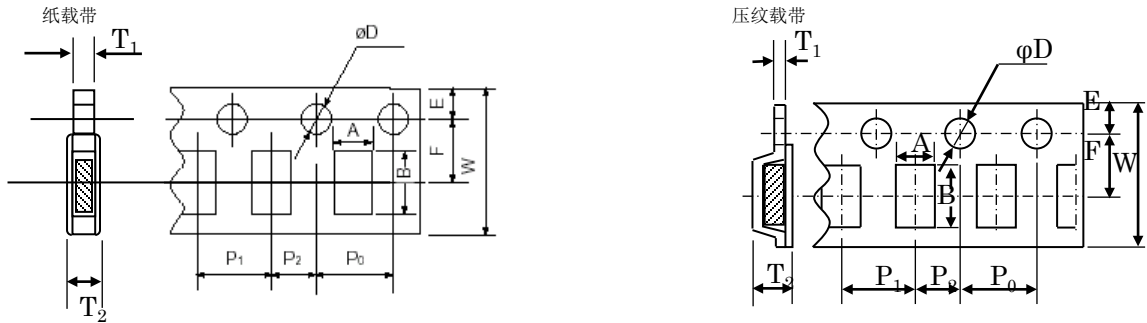

型号	专业载带材质	A	B	W	F	E	P <sub>1</sub>	P <sub>2</sub>	P <sub>0</sub>	D	T <sub>1</sub>	T <sub>2</sub>
		±0.1	±0.1	±0.3	±0.05	±0.1	±0.1	±0.1	±0.1	±0.1	-	-
10	纸	1.1	1.9	8.0	3.5	1.75	4.0	2.0	4.0	φ1.5	1.1 Max	1.4 Max.
20	压纹	1.65	2.4	8.0	3.5	1.75	4.0	2.0	4.0	φ1.5	0.6 Max	1.5 Max
30		2.0	3.6	8.0	3.5	1.75	4.0	2.0	4.0	φ1.5	0.6 Max	1.5 Max
40		2.8	3.6	8.0	3.5	1.75	4.0	2.0	4.0	φ1.5	0.6 Max	2.0 Max
70-1		3.6	4.9	12.0	5.5	1.75	8.0	2.0	4.0	φ1.5	0.6 Max	3.7 Max
70-2		4.4	5.3	12.0	5.5	1.75	8.0	2.0	4.0	φ1.5	0.6 Max	3.8 Max
80		5.4	6.1	12.0	5.5	1.75	8.0	2.0	4.0	φ1.5	0.6 Max	5.0 Max

### ■卷盘尺寸

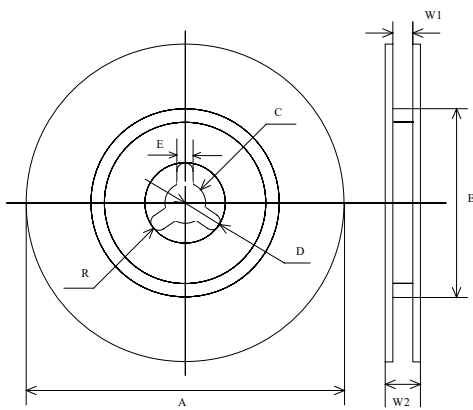

记号	尺寸 [mm]	
	型号	
	10, 20, 30, 40	70, 80
A	φ178±2	φ178±2
B	≥φ50	≥φ50
C	φ13.0±0.5	φ13.0±0.5
D	10.5±0.4	10.5±0.4
E	2.0±0.5	2.0±0.5
W <sub>1</sub>	10±0.5	14±0.5
W <sub>2</sub>	14±0.5	18±0.5
R	1.0	1.0

### ■标准部品收纳数量(个/卷)

型号	CVG10	CVG20
T(mm)	0.8±0.2	1.25±0.2
数量	4,000	3,000

型号	CVG30		CVG40		CVG80
T(mm)	1.0±0.2	1.25±0.2	1.0±0.2	1.25±0.2	3.5max.
数量	3,000	2,000	3,000	2,000	500

型号	CVT70	CVT85
T(mm)	3.5max	4.5max
数量	500	250